

SVPWM Control Strategy, D-STATCOM for Efficient Power Quality in Distribution System

Mohd Abdul Kareem¹, Dr Dalvindhar Kaur Mangal²

¹Research Scholar, Department of Electrical Engineering, SunRise University, Rajasthan.

²Professor, Department of Electrical Engineering, SunRise University, Rajasthan.

ABSTRACT:

In this paper, control system & operation of D-STATCOM is presented and the control technique used for voltage is Sinusoidal pulse width modulation & Space vector PWM. From project work comparison of total harmonic distortion in all power quality problems with SPWM and SVPWM are observed and improved. D-STATCOM modelled and simulated using MATLAB/SIMULINK software.

Keywords: - D-STATCOM, SPWM, SVPWM, voltage sag and swell, Harmonics, MATLAB/ SIMULINK, Bridge Inverter, Total Harmonic distortion (THD).

1. INTRODUCTION

D-STATCOM is a compensating device used to control flow of reactive power in distribution system. D-STATCOM is nothing but a STATCOM but used at distribution level. D-STATCOM is shunt connected voltage source converter which has been used in distribution network to compensate the bus voltage so as to provide improved power factor and reactive power control. It is connected in shunt to the distribution system through a standard power distribution transformer. D- STATCOM has the capability of providing quick and continuous capacitive and inductive mode compensation. D-STATCOM can inject sufficient amount of lagging or leading compensating current when it is associated with a specific load so that total demands meet the specification for utility connection. It can clean up the voltage from any unbalance and harmonic distortion. D-STATCOM plays vital role in radial distribution system due to increasing power system load. Optimum allocation of D-STATCOM maximises load ability, power loss minimization, stability enhancement, reactive power compensation & power quality enhancement such as voltage regulation, voltage balancing a flicker suppression system. D- STATCOM can be used in distribution system, wind power, solar power generation and also used with fuzzy system. D- STATCOM applications mainly for sensitive loads that may be drastically affected by fluctuations in the system. In this project D-STATCOM is used to control flow of reactive power after coming fault in distribution system and improve quality of power by decreasing effects of power quality problems with the help of SPWM/SVPWM technique.

Space vector pulse width modulation technique is an advanced, computation-intensive PWM method and is best among all the PWM techniques. SVPWM is a modulation scheme used to apply a given voltage vector to a three phase electric motor. The control of D-STATCOM is accomplished by SVPWM technique with potential of supplying reactive power, harmonics and unbalanced load compensation and it is used to provide real component of load current, Positive sequence and fundamental frequency. SVPWM is digital technique. SVPWM technique has been mostly applied in the current control of three phase voltage source inverter. It provides pulses to the D-STATCOM. It improves total harmonic distortion than SPWM technique. It provides more efficient use of supply voltage than SPWM technique. In this paper, SVPWM technique is used for generating PWM pulses for the D-STATCOM & improves total harmonic distortion.

YUVAENGINEERS

Transforming Young Engineers for Better Tomorrow

In this paper, D-STATCOM improves power quality by decreasing voltage sag & swell and control reactive power flow using control techniques SPWM and SVPWM. Total harmonic distortion in all nine power quality problems using SPWM and SVPWM technique is compared using D-STATCOM model.

2. D-STATCOM

It is a compensating device which is used to control the flow of reactive power and reduce harmonics in distribution system and based on voltage source converter (VSC). It absorbs or generates controllable active and reactive power. It consists of a two-level a dc energy storage device, Voltage Source Converter (VSC), a coupling transformer connected in shunt to the distribution network through a coupling transformer. Proper adjustment of magnitude and phase angle of DSTATCOM output voltages allows effective control of active and reactive power exchanges between the D-STATCOM and the ac system. In this paper, D-STATCOM is used to regulate the voltage at the point of connection. The control is based on space vector PWM and only requires the measurement of the rms voltage at the load point.

D-STATCOM based voltage source converter (VSC) is a power electronic device. This VSC can generate a sinusoidal voltage with any required phase angle, frequency and also for magnitude. It is most widely used in VFD and used to decrease the voltage drop. It is energy storage device. VSC used with D-SATCOM for power quality problems like harmonics and fluctuation.

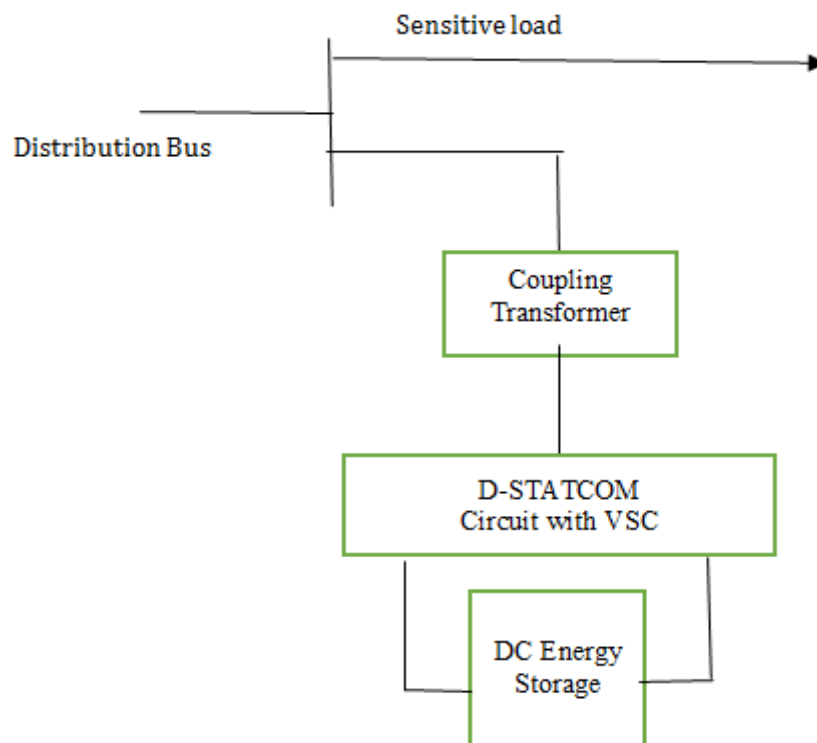

Fig.1: Constructional block diagram of D-STATCOM Operation of D-STATCOM

The D-STATCOM is a shunt connected custom power device connected across the load end of a distribution network. A capacitor, three phase inverter module, AC filter, coupling transformer and a controller are the basic components of it. The voltage source converter (VSI) helps to convert the input DC voltage to an output of three phase of AC voltage with constant frequency. The phase of the thyristor based inverter voltage (V_i) is maintained at controlling level of distribution system voltage (V_s).

YUVAENGINEERS

Transforming Young Engineers for Better Tomorrow

The three basic modes of operation of a D-STATCOM are as follows:

- i. When $V_i = V_s$, the reactive power become zero, it indicates that D-STATCOM neither generates nor absorbs any reactive power.
- ii. When $V_i > V_s$, it indicates an inductive reactance connected across the terminal of D-STATCOM. It represents inductive mode of operation. The current flows from a D-STATCOM to the AC system through transformer reactance. At this stage, the D-STATCOM generates capacitive reactive power.
- iii. When $V_i < V_s$, it indicates a capacitive reactance connected across its terminals. It represents capacitive mode of operation. Current flows from AC system to the D-STATCOM. In this case it absorbs inductive reactive power. Thus, the D-STATCOM can either absorb or deliver reactive power to the system.

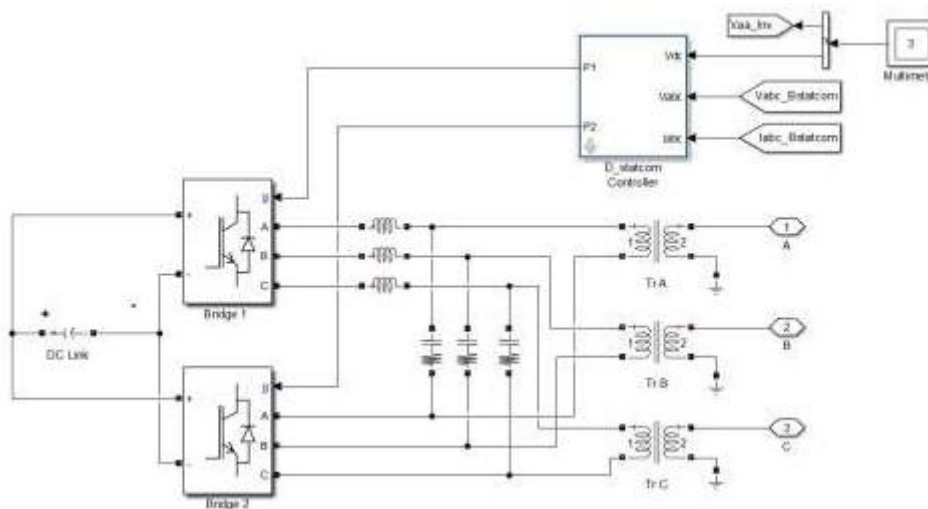

Fig.2.1: D-STATCOM control network

3. SVPWM

Space Vector pulse width Modulation (SVPWM) technique was originally developed as vector approach to Pulse Width Modulation (PWM) for three phase inverters. It is more sophisticated technique for generating sine wave that provides a higher voltage to the motor with lower total harmonic distortion. Space Vector PWM (SVPWM) technique is an advanced, computation intensive Pulse width modulation method and possibly the best technique for variable frequency drive application. In this paper, Space vector pulse width modulation is controlled D-STATCOM by providing gate triggering and with potential of supplying reactive power, harmonics and unbalanced load compensation and it is used to provide real component of load current, positive phase sequence and fundamental frequency. Space Vector PWM (SVPWM) technique refers to a special switching sequence of the upper three power transistors of a three-phase power inverter. It has been shown to generate less harmonic distortion in the output voltages and/or currents applied to the phases of an AC motor and to provide more efficient use of dc input voltage.

3.1 Operation of SVPWM

The circuit model of a three-phase voltage source PWM inverter is shown in figure 2. S1 to S6 are the six power switches which are controlled by the switching variables a, a', b, b', c and c'. When an upper transistor S1, S3 and S5 are switched on, i.e., when a, b or c is 1, the corresponding lower transistor S2, S4 and S6 are switched off, i.e. a', b' or c' is 0. Therefore, ON and OFF states of the upper transistors S1, S3 and S5 can be used to determine the output voltages.

YUVAENGINEERS

Transforming Young Engineers for Better Tomorrow

The objective of space vector PWM technique is to compare the reference voltage vector V_{ref} using the eight switching patterns. One simple method of comparison is to generate the average output of the inverter in a small period T to be the same as that of V_{ref} in the same period.

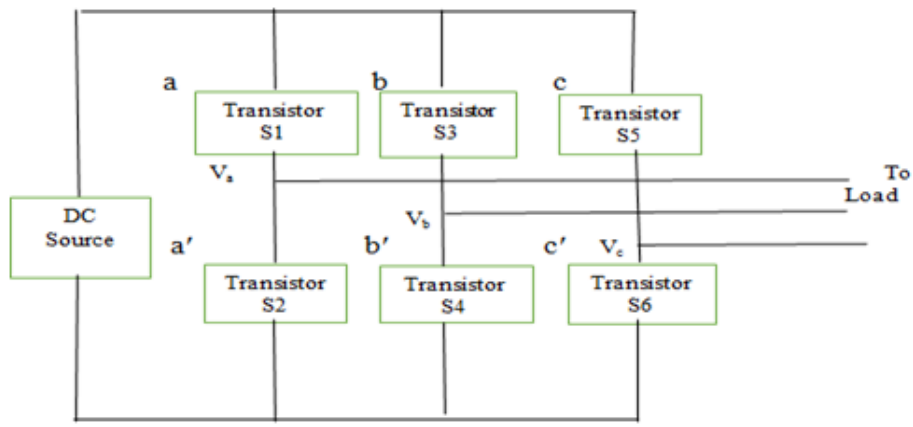

Fig.2 STATCOM Inverter

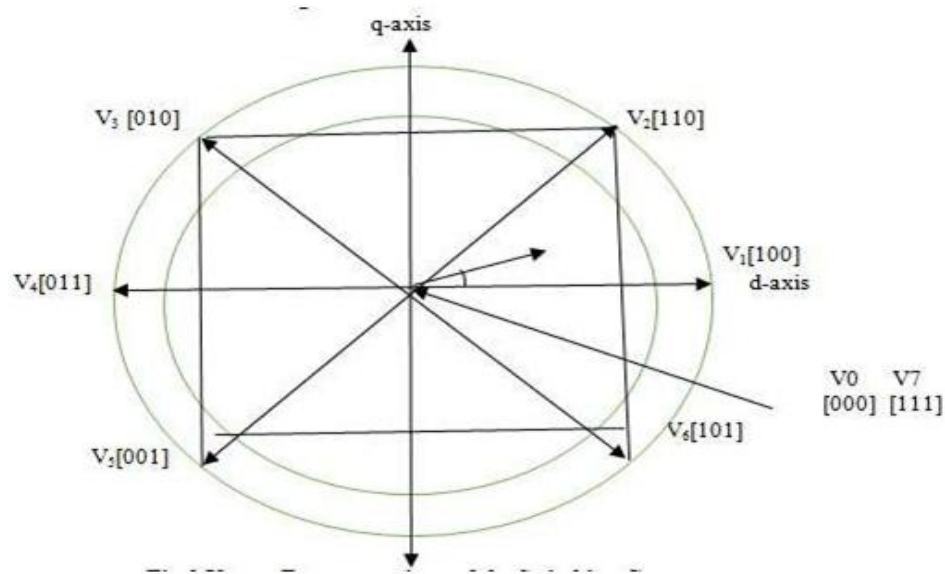

Fig.3 Vector Representations of the Switching Gate

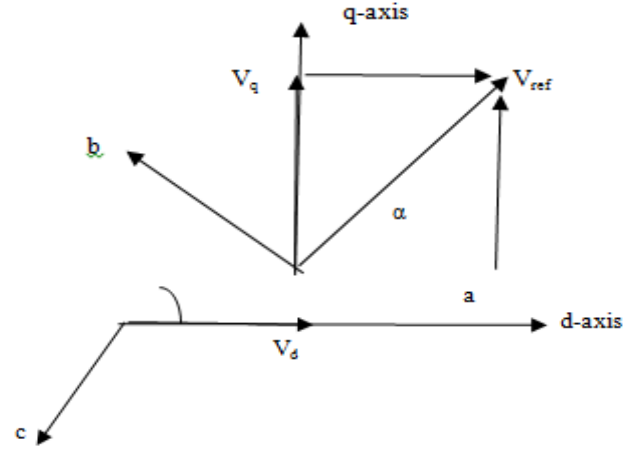

Fig.4: Voltage Space Vector and its Components

YUVAENGINEERS

Transforming Young Engineers for Better Tomorrow

From fig.4, V_d , V_q , V_{ref} , and angle (α) can be determined as follows:

$$\alpha = \tan^{-1} (V_d/V_q) \dots\dots\dots (3)$$

$$|V_{ref}| = (V_d^2+V_q^2) \dots\dots\dots(4)$$

4. METHODOLOGY

In this project, we used two system network with one D-STATCOM uses control techniques SPWM and SVPWM. Voltage and current of D-STATCOM is controlled by D-STATCOM bus which is input to D-STATCOM controller. In D-STATCOM controller network used Two Bridges such as positive bridge (Bridge 1) and negative bridge (Bridge 2). Positive bridge act as inverter by discharging of Capacitor and negative bridge act as rectifier by charging of capacitor. Three LC filters are introduced by the bridges to reduce harmonics by D-STATCOM. Transformer is used to convert low voltage (1250V) level to bridge voltage (25kV) level. The Controller takes feedback of D-STATCOM ac side voltage and currents and DC voltage across capacitor generating M_{ϕ} (modulation index/Amplitude) and w (angular frequency). These M_{ϕ} and w value calculates the reference value or signal for the sinusoidal pulse width modulation and space vector pulse width modulation. Disturbance in signal are reduced by anti aliasing filter. In case of sag condition fault block is used to create sag in the two port network system. The fault also affects the D-STATCOM and fails. In order to introduced sag, swell, harmonics in a small network system three phase programmable source is used. In case of swell condition, capacitance is used to create swell in the two port network system. The fault also affects the D-STATCOM and fails. In order to introduced sag, swell, harmonics in a small network system three phase programmable source is used. D-STATCOM control reactive power flow and compensate Voltage sag, Swell and harmonics. Total harmonic distortion is reduced more by SVPWM than SPWM technique which shows in result below.

5. PROJECT WORK

Power quality problems are improved by modelling and simulation of D-STATCOM based on bridge inverter with D-STATCOM controller using Space vector pulse width modulation (SVPWM) technique. Total harmonic distortion in all nine power quality problems are reduced using SVPWM technique than SPWM. To mitigate Voltage sag, voltage swell harmonics etc in distribution system. Simulation model of D-STATCOM with SPWM/SVPWM showed as follows,

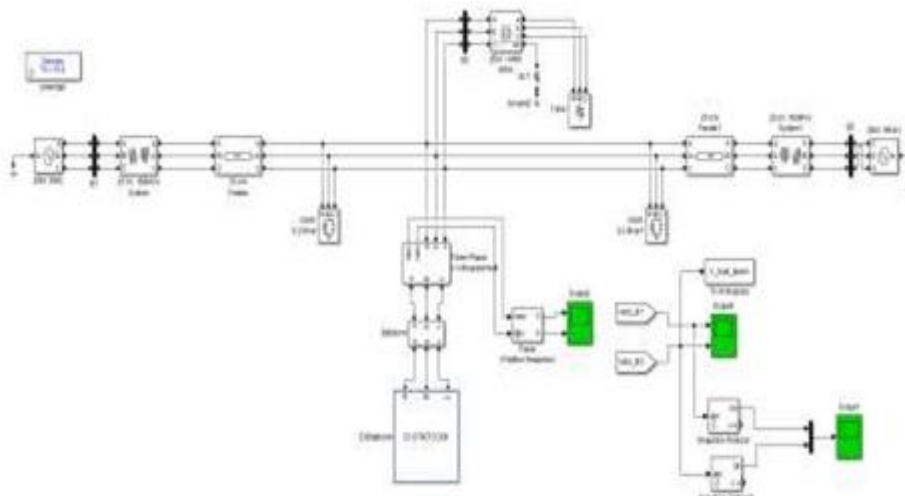

Fig.5: Simulation model of D-STATCOM using SPWM/SVPWM technique

YUVAENGINEERS

Transforming Young Engineers for Better Tomorrow

6. RESULT

Total harmonic distortion using SPWM & SVPWM with D-STATCOM comparison results to improve power quality are shown below,

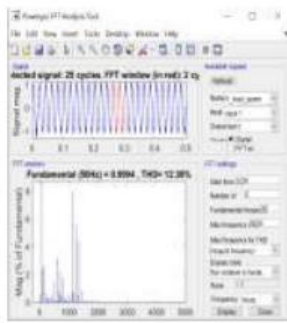

THD in Sag without D-STATCOM

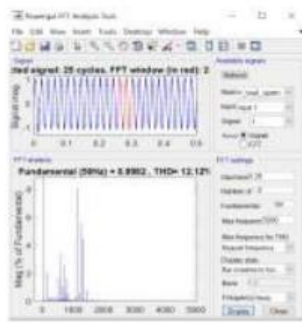

THD in Sag with D-STATCOM & SPWM technique

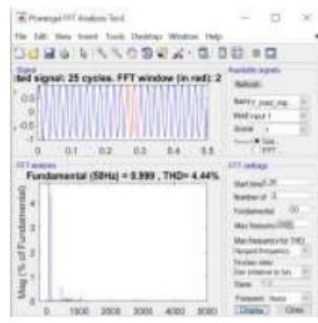

THD in Sag with D-STATCOM & SVPWM technique

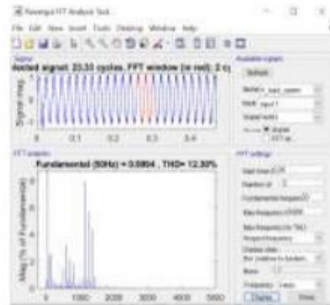

THD in Swell without D-STATCOM

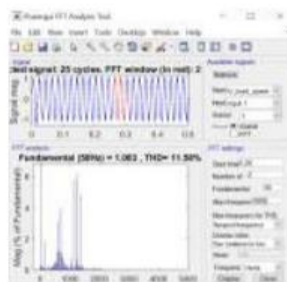

THD in Swell with D-STATCOM & SPWM technique

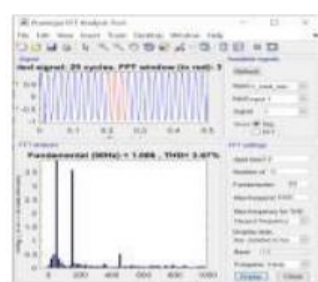

THD in Swell with D-STATCOM & SVPWM technique



THD in Harmonics Without D-STATCOM

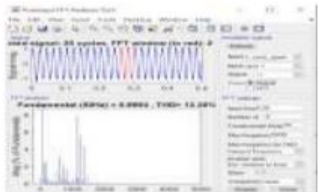

THD in Harmonics with D-STATCOM & SPWM technique

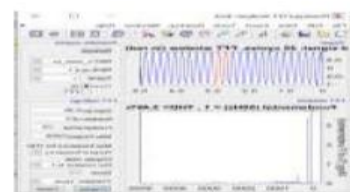

THD in Harmonics With D-STATCOM & SVPWM te

7. CONCLUSION

The modelling and simulation of D-STATCOM using MATLAB/SIMULINK has been presented. The performance of D- STATCOM is studied under voltage Sag and Swell by using SPWM/SVPWM techniques. From simulation results D- STATCOM compensates voltage sags & swells quickly and provides better voltage regulation in both cases. Space vector pulse width modulation technique effectively restored the voltage of sensitive load to normal and reduced the harmonic distortion in load voltage when compared with sinusoidal PWM. After simulation study showed that SPWM requires 15% more DC voltage when compared to SVPWM for the same output. For compensation of same amount of voltage sags & swells, SVPWM requires less amount of DC voltage as compared to SPWM. So that by using SVPWM technique dc voltage required for inverter is less when compared to sinusoidal PWM technique in order to generate same amount of output. Harmonics in the output voltage are reduced by using Space Vector PWM technique as compared to SPWM technique. Total harmonics distortion are completely removed by using D-STATCOM with LCL filter circuit.

YUVAENGINEERS

Transforming Young Engineers for Better Tomorrow

8. REFERENCES

- [1] H. Akagi, "Classification, terminology, and application of the modular multilevel cascade converter (MMCC)," IEEE Trans. Power Electron., vol. 26, no. 11, pp. 3119–3130, Nov. 2011...
- [2] Keyur R. Kinariwala, Piyush K. Patel, Kapildev N. Arora, "Compensation of Reactive Power using STATCOM in Distribution Network", International Journal of Emerging Technology and Advanced Engineering (ISSN 2250-2459, ISO 9001:2008 Certified Journal, Volume 5, Issue 3, March 2015).
- [3] P. Dineshkumar, Prof. D. Prakash, Dr. R. Mahalakshmi, "Closed Loop Reactive Power Control by A SPWM STATCOM Based On Modular Multilevel Cascade Converter for Electric Welding Machine Conference", International Journal of Engineering Research & Technology (IJERT), ISSN: 2278-0181, Vol. 2 Issue 11, November - 2013.
- [4] Sawicki. A, Switon. Ł and Sosinski. R, „Process Simulation in the AC Welding ArcCircuit Using a Cassie-Mayr Hybrid Model", American Welding Society and the Welding Research Council, Mar 2011.